

Research Article

A spatiotemporal data model for river basin-scale hydrologic systems

JONATHAN L. GOODALL*† and DAVID R. MAIDMENT‡

†Department of Civil and Environmental Engineering, University of South Carolina,
Columbia, SC, USA

‡Department of Civil, Architectural, and Environmental Engineering, University of
Texas, Austin, TX, USA

(Received 1 October 2007; in final form 18 January 2008)

Despite a long history of synergy, current techniques for integrating Geographic Information System (GIS) software with hydrologic simulation models do not fully utilize the potential of GIS for modeling hydrologic systems. Part of the reason for this is a lack of GIS data models appropriate for representing fluid flow in space and time. Here we address this challenge by proposing a spatiotemporal data model designed specifically for large-scale river basin systems. The data model builds from core concepts in geographic information science and extends these concepts to accommodate mathematical representations of fluid flow at a regional scale. Space–time is abstracted into three basic objects relevant to hydrologic systems: a control volume, a flux and a flux coupler. A control volume is capable of storing mass, energy or momentum through time, a flux represents the movement of these quantities within space–time and a flux coupler insures conservation of the quantities within an overall system. To demonstrate the data model, a simple case study is presented to show how the data model could be applied to digitally represent a river basin system.

Keywords: Hydrology modeling; GIScience; Spatiotemporal data modeling; Data integration

1. Introduction

River basin-scale water resource systems require a substantial amount of data to adequately reconstruct the natural environment in a digital form. The volume of data is such that scientists and engineers are typically reliant on data products produced and maintained by outside organizations and individuals to model and understand how a system functions. This dependence on the data of others introduces information integration challenges for the water community, challenges such as data standardization, data fusion and automated access, which are critical to scientific progress toward managing water resources in a sustainable way.

Geographic Information Systems (GIS) have emerged as a critical tool in hydrology, in large part because of these information integration challenges. The technology provides a consistent spatial framework and spatial analysis tools that allow modelers to gain access to base geospatial datasets such as land use, soils and terrain, and to derive inputs from these data for their simulation models. Researchers have proposed a variety of means for coupling a GIS with a hydrology

*Corresponding author. Email: goodall@enr.sc.edu

model in order to either speed model development time or improve a model's spatial representation (Clark 1998; Martin *et al.* 2005; Sood and Bhagat 2005; Srinivasan and Arnold 1994; Tim and Jolly 1994). These past approaches can be broadly grouped into three categories: (1) embedding a GIS within a model (or *vice versa*); (2) writing custom software to perform hydrologic modeling routines within a GIS; (3) automating the exchange of files between the GIS and a model (Martin *et al.* 2005).

While these past approaches for coupling GIS and hydrology models do present a way of harnessing the potential of a combined GIS and hydrologic modeling system, they are often highly pragmatic in how they couple two otherwise independent software systems. The typical approach has been to build from existing GIS software technology without consideration of how that software might be altered to better accommodate hydrologic modeling. While in practice, it is often necessary to take this approach to quickly and inexpensively build robust systems, the approach is limiting and restrictive for many hydrologic applications and is therefore not a suitable long-term solution. We, along with others (Maidment 1996; Sui and Maggio 1999), argue that the basic disconnection between GIS and hydrology models is due to the fact that current GIS software does not include a data model appropriate for representing hydrologic processes, which implicitly limits the types of hydrology models that can be developed within a GIS context.

For this reason, we propose a new spatiotemporal data model that incorporates ideas from geographic information science as the basis for creating a river basin-scale modeling system. The data model provides new building blocks for constructing a digital representation of a river basin system that begins with concepts such as entities and fields, but extends these concepts to better align with existing hydrologic modeling concepts such as control volumes, fluxes, and flows (Reckhow *et al.* 2004). This data model provides a generic base from which hydrologic models that make full use of geospatial analysis algorithms could be constructed.

2. Background

2.1 Representations of hydrologic space-time

There are two basic views of space in geographic information science: space as comprised of discrete entities and space as a continuous field (Burrough and McDonnell 1998; Goodchild 1992). Spatial data models most often implement one of these two basic views of space. For example, a vector data model considers space as a set of entities, each with a discrete geometry and set of attributes, whereas a raster data model views space as a continuous field that is sampled and recorded at a set of fixed locations. Both vector and raster data models are useful for river basin-scale hydrology applications. Watersheds, rivers and waterbodies are often best represented as entities using a vector data model, while terrain, precipitation and land-use are often best represented as a continuous field using a raster data model.

However, although both data models are useful for hydrology applications, neither is ideally suited to meet the basic needs of representing hydrologic phenomena. Many researchers have discussed limitations between coupling GIS with hydrology models (Clark 1998; Srinivasan and Arnold 1994; Sui and Maggio 1999). A fundamental shortcoming is that these data models lack an appropriate means for representing the transfer of mass, energy and momentum in space and time. This is in part because existing GIS data models do not include a

representation of time (Langran 1992, 1993; Peuquet 2001), but also because they do not accommodate basic conceptualizations implemented in mathematical models of hydrologic systems such as control volumes, fluxes and mass balances. These basic hydrologic conceptualizations used in hydrologic simulation models have been formulated through the community's development of simulation models and are, therefore, better suited for hydrologic analysis when compared to the current data models available in GIS software.

Despite a near absence of a temporal dimension in most GIS software, various spatiotemporal data models have been proposed in literature (Erwig and Schneider 2002; Peuquet and Niu 1995; Rasinmaki 2003) and file formats exist for storing spatiotemporal data. For example, the Network Common Data Form (NetCDF), which is commonly used in the atmospheric community to store model output from numerical simulations, implements the concept of storing data in a multidimensional array that can be both spatial and temporal (Rew and Davis 1990). The Geographic Markup Language (GML) contains another example of a spatiotemporal data model, as evident by its specification for dynamic features (Cox *et al.* 2004). A dynamic feature is implemented using time stamped instances of a feature with each instance describing the location and properties of that feature at that moment in time. NetCDF and GML demonstrate the potential of a spatiotemporal data model for hydrology.

Researchers have proposed geographic data models for hydrology that address shortcomings in current GIS data models to various degrees, but these data models are often specific for one hydrologic modeling system. Band *et al.* (2000), for example, express a set of hierarchical spatial objects for representing hydrologic structure and dynamics (i.e. world, basin, hillslope, zone, patch, etc.) and provide a geographic foundation for the RHESSys watershed model. Likewise, Wang *et al.* (2005) describe an object-oriented approach for representing and stimulating a watershed system built from the TOPMODEL hydrologic model. Our approach is different in that we propose classes that are specially designed to support interoperability between multiple modeling systems.

ArcHydro (Maidment 2002) is perhaps the best example of a spatiotemporal data model of hydrology with the same objective of interoperability, but because ArcHydro is derived from ESRI ArcObject classes, ArcHydro developers were required to create spatiotemporal objects through relationships between feature classes and an object class that stores temporal information. For example, time series values stored in the TimeSeries object class are related to a station feature stored in the MonitoringPoint feature class (Figure 1). Here we envision a deeper integration of space, time and processes through which hydrologic concepts, like those expressed in ArcHydro, could be more easily implemented. While this approach would require a programming of GIS software to accommodate natively spatiotemporal objects, we believe that it is necessary to advance hydrologic modeling with GIS.

2.2 Hydrologic simulation modeling

Our design of a generic spatiotemporal data model for the hydrologic sciences draws from both geographic information science as well as a conceptual understanding of hydrologic simulation modeling. Hydrologic simulation models data from early conceptualizations like the Rational Method (Chow *et al.* 1988), a method to estimate the peak streamflow resulting from a precipitation event, to present day computer codes such as SWAT, HSPF and HEC-RAS. There are hundreds of

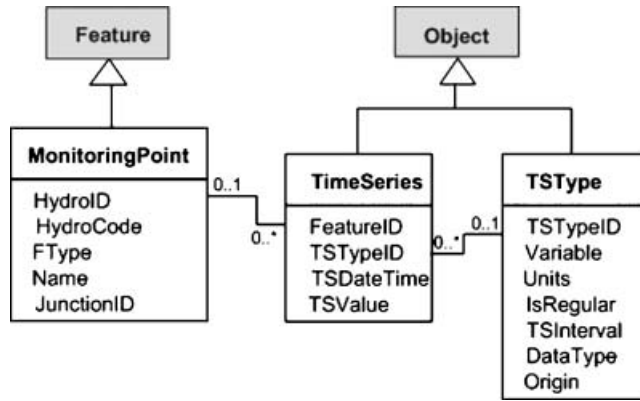

Figure 1. Link between space and time in the ArcHydro schema.

simulation models available for predicting various processes within an overall hydrologic system (Singh and Woolhiser 2002). Each model is tailored for some spatial and temporal scale, and to address some scientific or management question.

One way of classifying the existing hydrologic simulation models is by whether their spatial frame of reference is Eulerian or Lagrangian (Maidment 1996). The Eulerian approach uses a fixed space referencing system where mass and energy travel through a defined region of space over time. In contrast, the Lagrangian approach uses a relative referencing frame where the focus is on following a particular particle as it travels through a system. Surface water models most often implement an Eulerian view of space where the model consists of fixed elements (often called hydrologic response units). The Lagrangian view is used to a lesser extent with examples being particle tracking tools where a ‘slug’ of mass is released at some location and the model simulates how that slug changes as it travels through the environment.

Taking a Eulerian approach for analyzing fluid flow, the Reynolds Transport Theorem can be used to describe how a defined region of space, or a control volume, stores mass, momentum or energy through time (Chow *et al.* 1988). If B is either the property mass, momentum, or energy, then the rate of change of B within a system (sys) is given by equation (1) where ρ is the fluid density, b is amount of the fluid property per unit mass, V is the control volume, \vec{v} describes the fluid velocity as a vector, \hat{n} is a unit vector normal to the control surface and A is the control surface. The integrations in equation (1) are performed over three-dimensional control volume (cv) and two dimensional control surface (cs) of the control volume, respectively

$$\frac{dB_{sys}}{dt} = \frac{d}{dt} \int_{cv} \rho b dV + \int_{cs} \rho b \vec{v} \cdot \hat{n} dA \quad (1)$$

Using the Reynolds Transport Theorem, one can derive a water budget by letting B equal the mass of water m and therefore, because b is the amount of fluid property per unit mass, it reduces to 1

$$\frac{dm_{sys}}{dt} = \frac{d}{dt} \int_{cv} \rho dV + \int_{cs} \rho \vec{v} \cdot \hat{n} dA \quad (2)$$

This equation provides the basic modeling structure for calculating a water balance within a GIS. It states that the amount of mass stored within a fixed boundary system is equal to the rate of change of mass within the control volume ($d\int_{cv}\rho dV/dt$), plus the rate at which mass is being transferred across the system's boundaries ($\rho\int_{cs}\vec{v}\cdot\hat{n}dA$). One can derive similar expressions for energy and momentum also using the Reynolds Transport Theorem (Chow *et al.* 1988).

3. Data model design

3.1 Conceptual design

The Reynolds Transport Theorem consists of two basic conceptualizations of space–time. The first concept is a control volume: an entity able to store mass, energy or momentum through time. The second concept is a flux. A flux represents the transfer of mass, energy or momentum over space and through time. We argue that space–time can be modeled as a set of control volume and flux objects, where each control volume may be related to one or more flux objects. The flux objects that are related to a control volume object describe the exchange of mass, energy or momentum into or out of that control volume. To ensure conservation within the overall system, a third concept is needed to specify this coupling between fluxes and control volumes to ensure that the flux from one control volume is accounted for as a flux into another control volume (or volumes).

Defining a river basin system as a set of control volumes and fluxes can be carried out at a variety of spatial and temporal scales. A control volume could be defined for a continental-scale river basin or an individual grid pixel. Furthermore, it is possible to represent space as a hierarchy of control volumes where one control volume is the agglomeration of other, smaller control volumes. For example, a catchment could be viewed as a control volume where the exchanges of water into and out of that catchment occur across its land–atmosphere and subsurface interfaces, and by stream discharge into and out of the catchment. Within a catchment system, one could define a set of embedded control volumes that might include such entities as waterbodies or stream channels. The choice as to what to consider as a unique control volume is left to the modeler and primarily has to do with the scientific question or management goal at hand. If one wishes to gain explicit knowledge of the storage of water within a waterbody through time, the waterbody must be considered as a control volume within the system and not be lumped into a larger system.

Control volume objects are coupled by the transfer of mass, energy or momentum through the spatial intersection of their control surfaces. Many existing models employ a simple spatial structure where cells of a numerical grid share a common spatial interface. In this case, the flux between control volumes is computed without an explicit consideration of space. When control volumes are misaligned in space, however, a spatially-explicit treatment of transfers becomes important to correctly partition mass, energy or momentum between control volumes. Consider the case where a watershed model is coupled to an atmospheric model through the exchange of precipitation and evapotranspiration (Figure 2). A grid cell in the atmospheric model may only partially intersect the receiving watershed control volume, as shown by the highlighted cell in Figure 2. Using the spatial context for the control volumes, it is possible to derive the fraction of a quantity transferred between the two control volumes when they only partially intersect.

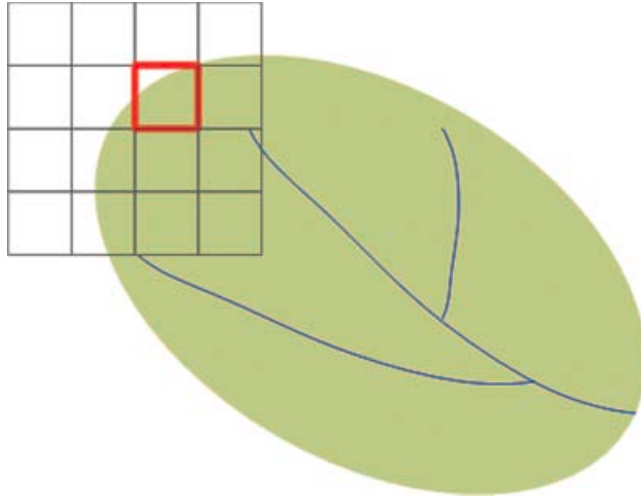

Figure 2. An example of spatial misalignments between hydrology modeling units: A watershed with a cell mesh representing atmospheric modeling units.

A spatially-explicit representation of fluxes associated with control volumes also requires a careful consideration of dimensions in space, time and measurement units. A flux is a spatiotemporal quantity, meaning that it has both a spatial geometry that represents the point, line, or area over which the measurement is applied, and a temporal geometry that represents the instant or interval of time for which the measurement is valid (Erwig and Schneider, 2002; Yuan 2004) (Figure 3). A flux also has measurement dimensions that define the quantity being observed

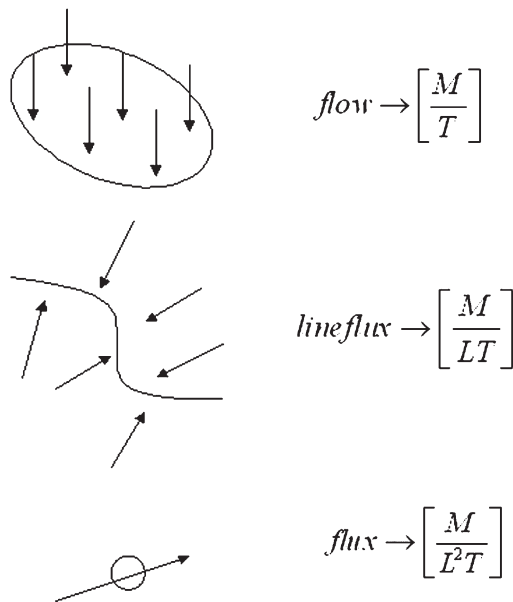

Figure 3. The combination between a flux's measurement dimensions and spatial dimensions allows for translation between heterogeneous data sources.

Table 1. Possible fluxes with varying spatial, temporal and measurement dimensions.

(a) dimensions for space–time geometries		
	Temporal dimension	
	0-D: instant	1-D: interval
0-D: point	$M/L^2/T$	M/L^2
1-D: line	$M/L/T$	M/L
2-D: polygon	M/T	M
(b) names for space–time geometries (assuming that mass is the property)		
	Temporal dimension	
	0-D: instant	1-D: interval
0-D: point	Flux	Mass per unit area
1-D: line	Line flux	Mass per unit length
2-D: polygon	Flow	Mass

(mass, energy, etc.) over space and through time (Figure 3). These three dimensions, space, time and measurement, must be carefully considered when defining a set of valid flux objects (Table 1). For example, if a flux is defined continuously over space, it should have measurement dimensions of ‘per unit area’. Likewise, if the flux varies continuously through time, it should have units of ‘per unit time’. Considering fluxes as spatiotemporal objects with a description in space, time and measurement dimensions offers the potential to automatically transform heterogeneous measurement units and dimensions in preparation for model calculations. For example, a flux defined for a set of points can be transformed with a polygon geometry into a spatially averaged flux (or a flow) that represents the amount of a quantity transferred across a control surface. Table 2 presents possible transformations between fluxes, and the space–time geometry needed to perform the transfer.

3.2 Logical design

Given this conceptual design, we propose three core concepts for representing hydrologic space–time: a flux, a control volume and a flux coupler (Figure 4). Together these three basic concepts describe the movement and state of mass, energy and momentum within a hydrologic system. Conservation of mass, energy and momentum are ensured by coupling control volumes so that the flux leaving one control volume becomes an input to other control volumes. The data model does

Table 2. Conversions between fluxes and the space–time geometry needed for the conversion.

From	To	Conversion geometry
$M/L^2/T$	$M/L/T$	Line
$M/L/T$	M/T	
M/L^2	M/L	
M/L	M	Interval
$M/L^2/T$	M/L^2	
$M/L/T$	M/L	
M/T	M	Polygon
$M/L^2/T$	M/T	
M/L^2	M	
$M/L^2/T$	M/L	Interval–line
$M/L/T$	M	Interval–polygon
$M/L^2/T$	M	

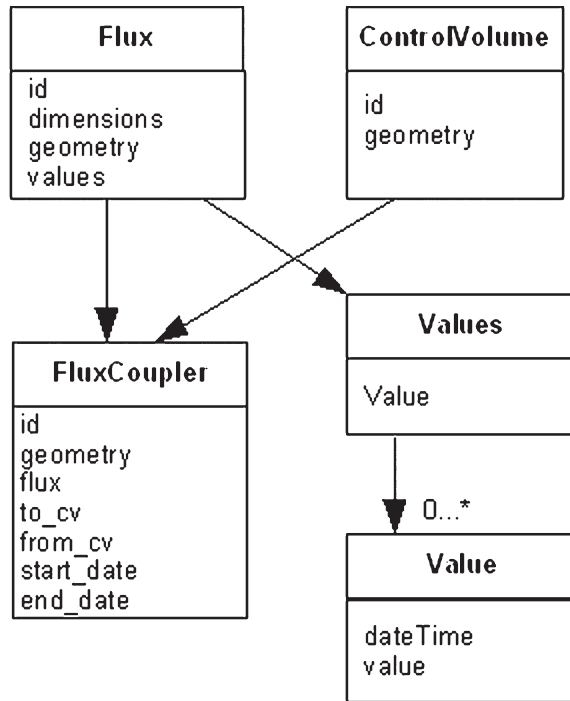

Figure 4. The proposed spatiotemporal data model for representing hydrologic systems at the river basin scale.

not assume that control volumes are perfectly aligned in space, so mass balance calculations could use the spatial intersection between the geometry properties of a flux coupler object to calculate the contribution of a flux from one control volume to a second control volume. These types of calculations would be possible because the system is built from GIS concepts where all objects are spatially referenced enabling the use of spatial calculations like intersections, interpolations and aggregations.

A *flux object* describes the transfer of mass, energy or momentum between control volumes. Conceptually, a flux can be represented using either a discrete entity or continuous field view of space. For a discrete entity, the flux has been integrated over some region of space (either a line or area) and therefore represents a spatially averaged value. The measurement units of an entity flux must correspond with the spatial dimensions of its associated geometry. For example, a flux object associated with a polygon becomes a flow object with units of mass, energy or momentum per unit time because the flux has been integrated over a two-dimensional surface (Table 1). A flux could also be associated with a line geometry forming a line flux with units of mass, energy or momentum per unit length per unit time. As a continuous field, a flux is associated to a point in space (which can be thought as a sample of the continuous function) and represents a value with units of per unit time per unit area.

A *control volume object* describes a region of space capable of storing mass or energy. Unlike a flux, a control volume must be represented using an entity view of space (because a field has no volume), but it can be implemented using either point geometries, pixels or tessellations. As a geometry, the control volume could

represent a complex, three-dimensional region of space such as a river channel or a catchment extending from the land surface to the water table. As a pixel or tessellations, the control volume represents a discretized region of space where each discretization is able to store quantities through time. In this case, the pixel or tessellation would represent a three-dimensional volume using a depth attribute associated with each pixel or tessellation object. An example would be a digital elevation model (DEM) or a triangulated irregular network (TIN) where each pixel in the DEM or each triangle in the TIN represents a volume of space extending to some depth above or below a reference height.

The relationship between control volumes in terms of the fluxes of material transferred between them is described by a *flux coupler object*. The flux coupler object is added to ensure conservation of mass, energy and momentum within an overall system by ensuring that flux objects describe both the transfer of a property to and from control volumes. A flux coupler can be thought as a relationship between control volume objects. While a flux describes the *movement* of material in space and time, a flux coupler describes the *transfer* of material between control volumes. Thus, a flux coupler consists of a flux object, a source control volume object and a destination control volume object. It also includes a geometry object which is the intersection (control surface) through which the transfer occurs.

4. Implementation of the data model: a case study for the Neuse River Basin, North Carolina

In the following case study the proposed data model is a sample implementation to the Neuse River Basin in North Carolina (Figure 5). In this case study, the objective is to represent the river basin system in terms of control volume, flux and flux coupler objects. This representation allows modelers to more easily derive new properties from the data, such as the rate of change of water storage within a control volume, because hydrologic models can be written to operate on the proposed data model. Likewise, GIS software could be modified to access and visualize the geospatial components of the data model, or to perform spatial calculations or analysis. GIS and hydrology models are coupled, therefore, through a common data model that includes a more robust representation of hydrologic processes in space-time.

For this case study, we populated the data model by starting with the 20 United States Geological Survey (USGS) streamflow gaging stations within the Neuse River Basin that have at least 10 consecutive years of daily discharge values. Terrain processing was then used to generate a single flow path, eight directional flow direction grid from the 30m National Elevation Dataset (<http://ned.usgs.gov>). We calculated the subwatershed drainage area for each station from the flow direction grid using the monitoring stations as seed points. Seed points represent the outlets of subwatersheds. Each subwatershed is therefore the incremental drainage area between adjacent seed points on the river network. These subwatersheds represent control volumes within our proposed data model framework, and the stations represent flux objects.

Consider the subwatershed highlighted in Figure 5. This subwatershed represents the area draining the land surface upstream of one USGS gage (02089000) and downstream of three USGS gages (02088000, 02088500 and 02087359). We considered six fluxes associated with this control volume (three inflows, one outflow, precipitation and evaporation) and created six flux coupler objects to describe each exchange between the watershed control volume and other control

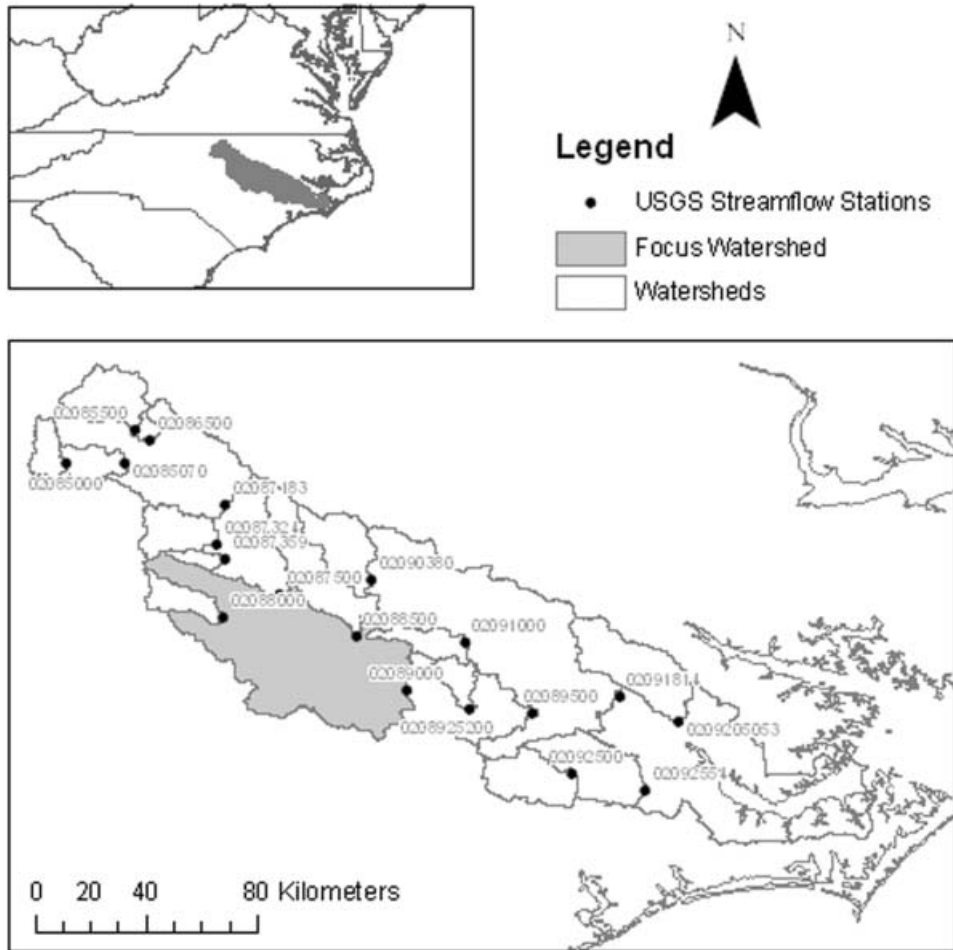

Figure 5. Case study area: the Neuse River Basin in North Carolina. The watersheds were derived from 20 USGS streamflow monitoring stations.

volumes within the system (Figure 6). This relationship between control volumes and fluxes can be captured in an Extensible Markup Language (EML) document that follows the data model terminology (Figure 7). The root element in the document is *system*, and a system element can have one or more *control volume*, *flux* and *flux coupler* child elements. A control volume is related to one or more flux elements through the ID attribute of the flux. This structure provides the ability to store spatiotemporal data about a river basin system and to provide a description of the transfer of material between control volumes within the system.

In order to estimate change in storage through time for the watershed, historical daily averaged streamflow measurements were obtained from the USGS National Water Information System (<http://water.usgs.gov/nwis>). Precipitation and evaporation fluxes were also obtained from the North American Regional Reanalysis (NARR) program (<http://www.emc.ncep.noaa.gov/mmb/rrean1>). The NARR program makes use of the current land-surface and atmospheric models to reforecast past weather conditions, while also assimilating past weather observations from various sites throughout North America to improve model predictions.

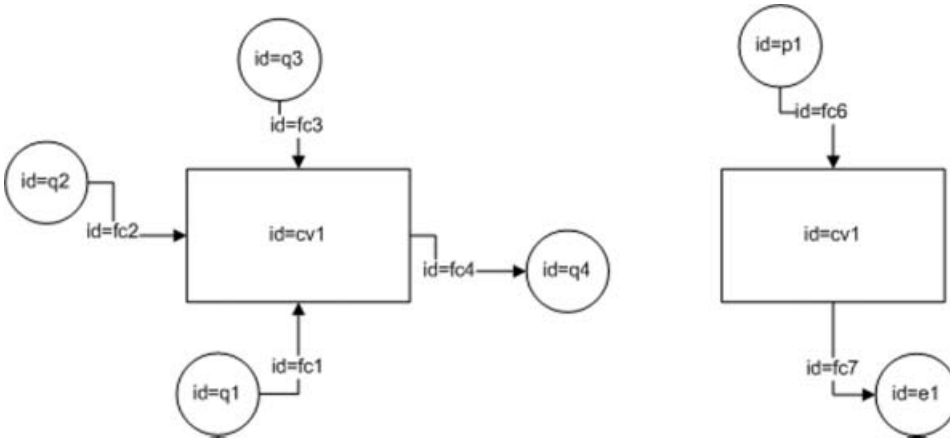

Figure 6. Schematic representation of a control volume in the study domain. The image on the right represents the streamflows entering and exiting the control volume (q=flow, cv=control volume and fc=flux coupler), while the figure on the right represents the horizontal fluxes (p=precipitation, e=evaporation, cv=control volume and fc=flux coupler).

```

- <hydroSystem>
  - <flux id="Q1" dimensions="L3T-1">
    + <geo>
    - <values>
      - <value dateTime="2005-01-01T00:00:00">10</value>
      ...
    </values>
  </flux>
  + <flux id="Q2" dimensions="L3T-1">
  + <flux id="ET1" dimensions="MT-1">
  + <flux id="P" dimensions="MT-1">
  - <controlVolume id="cv1">
    + <geo>
    - <volume units="m3">12350</volume>
    ...
  </controlVolume>
  <fluxCoupler id="fc1">
    + <geo>
    - <flux>f1</flux>
    - <from_cv>cv1</from_cv>
    - <to_cv>cv2</to_cv>
    + <start_date>
    + <end_date>
  </fluxCoupler>
</hydroSystem>

```

Figure 7. An XML representation of the same control volume. A plus sign signifies that the element has not been expanded to show its contents and an ellipse signifies addition elements could be inserted to the document.

Streamflow values are recorded by the USGS in units cubic feet per second. This represents a volume of water per unit time transferred through a channel cross section. It is possible to estimate a mass flux from these volume flow values by assuming a density of water, which is a function of the water temperature. Each streamflow time series represents a flux into one subwatershed and out of a second watershed. A flux coupler object accounts for this transfer of mass from the source watershed to the destination watershed. Precipitation and evaporation are also fluxes occurring across the boundary of the control volumes and are therefore also represented as flux coupler objects in the description of the system. NARR provides these fluxes in dimensions mass per unit area, accumulated over a 3 hour time span. The values were divided by 3 hours and multiplied by the watershed area to transform the dimensions into mass per time.

Using these data, change in storage through time (dS/dt) was estimated for the example subwatershed using the algorithm presented in Figure 8. Thus, the fluxes for the control volume were converted into consistent dimensions and units and summed on a daily time step. The results (Figure 9) clearly show the wet (where $dm_{sys}/dt > 0$) and dry (where $dm_{sys}/dt < 0$) periods for the subwatershed and provide a sense of the severity of droughts through an estimation of a water deficit. This process could be repeated for all subwatersheds within the basin to understand how various regions of the system store water through seasons. It could also be repeated over a longer temporal domain to identify periods and severity of droughts within the basin.

As evident by this simple example of a hydrologic model that operates from the proposed data model, there are important issues of data transformations that must be performed to ensure that a mass balance is calculated correctly. For example, if a flux is not in the dimensions of mass per time, then a calculation is needed to transform the flux into these dimensions before any water balance calculations. The proposed data model is intentionally generic and capable of storing multiple measurement dimensions and units. Data preparation calculations, such as unit conversions, interpolations or integrations, could be systemized and expanded to

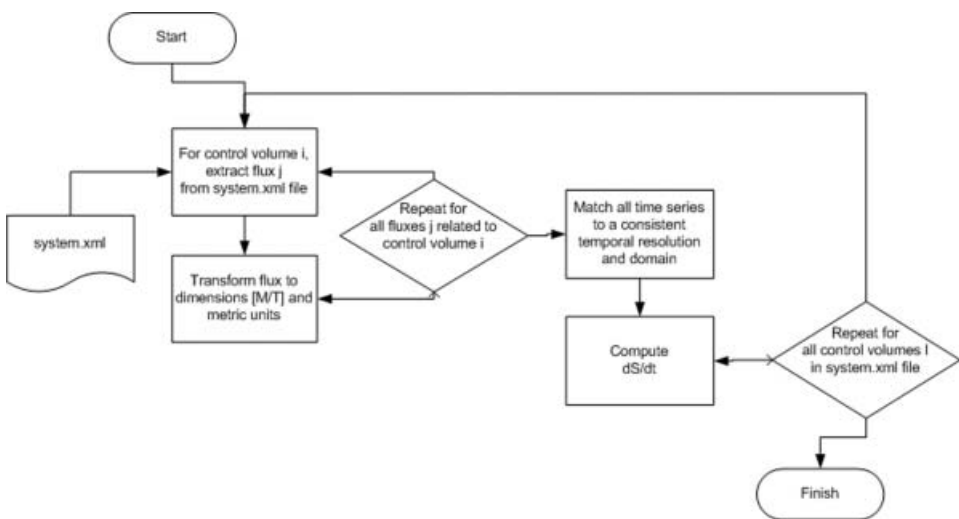

Figure 8. Algorithm for calculating change in storage through time from the proposed data model.

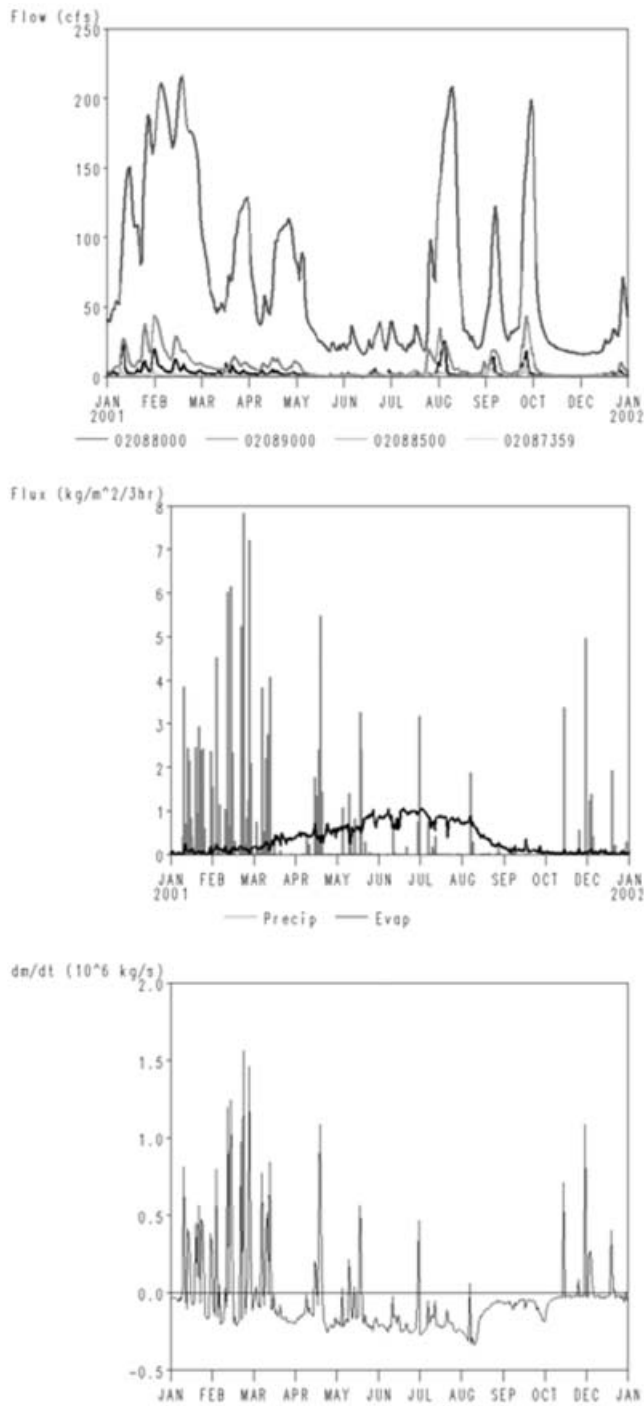

Figure 9. Plots of streamflow (a), precipitation and evaporation fluxes (b) and change in storage through time (c).

provide a suite of tools for analyzing river basin systems. The data model would provide the necessary metadata to enable modeling or analysis software to perform its own interpreting and transformations of the data before analysis and make it simpler for scientists to share either own models and analysis tools.

5. Summary

The proposed data model for hydrologic systems combines concepts from geographic information science and hydrologic science to better enable hydrologic modeling within GIS. Using the data model, a hydrologic system can be constructed from basic concepts that define where water is (control volumes), where water moves (fluxes) and how it is transferred between stores (flux coupler). This data model provides a view of space–time that is consistent with both hydrology models and geographic information science concepts. This means that software for hydrologic modeling and GIS can be written from the data model providing a new level of integration between hydrology models and GIS.

From the view of geographic information science, the primary benefit of this data model is that it provides an improved representation for fluid flow within geographic space. Instead of using generic GIS concepts of features and grids, the proposed data model introduces concepts of fluxes, control volumes and flux couplers. From the view of the hydrologic modeler, the primary benefit of the system is that it provides the ability to harness spatial analysis routines available in GIS software by enforcing a spatially-explicit representation of hydrologic systems within the model design itself. One can use this spatial referencing to understand the coupling between spatially-misaligned control volumes, to operate on values with different unit dimensions (mass per time, mass per area per time, etc.) and to integrated or aggregate values across spatial and temporal scales.

Future work will be aimed at creating hydrologic modeling and GIS software necessary to operate on the proposed data model. This effort should make use of existing software products to the extent possible, but not be limited by how these existing software system abstract space and time. Ultimately, the goal is to envision a new generation of hydrology models and GIS software that are written from spatiotemporal data models like the one proposed here. This would allow science and engineering applications to more fully capture real-world hydrologic processes in space and time with accurate digital representations.

References

- BAND, L.E., BRUN, S.E., FERNANDES, R.A., TAGUE, C.L. and TENENBAUM, D.E., 2000, Modelling watersheds as spatial object hierarchies: structure and dynamics. *Transactions in GIS*, **4**, pp. 181–196.
- BURROUGH, P.A. and McDONNELL, R., 1998, *Principles of Geographical Information Systems* (New York: Oxford University Press).
- CHOW, V.T., MAIDMENT, D.R. and MAYS, L.W., 1988, *Applied Hydrology*. McGraw-Hill series in water resources and environment engineering (New York: McGraw-Hill).
- CLARK, M.J., 1998, Putting water in its place: a perspective on GIS in hydrology and water management. *Hydrological Processes*, **12**, pp. 823–834.
- COX, S., CUTHBERT, A., LAKE, R. and MARTELL, R., 2004, *Geography Markup Language (GML) 3.1.1 OpenGIS Implementation Specification* (Wayland, MA: OGC).
- ERWIG, M. and SCHNEIDER, M., 2002, Spatio-temporal predicates. *IEEE Transactions on Knowledge and Data Engineering*, **14**, pp. 881–901.

- GOODCHILD, M.F., 1992, Geographical data modeling. *Computers and Geosciences*, **18**, pp. 401–408.
- LANGRAN, G., 1992, *Time in geographic information systems*. Technical issues in geographic information systems (London/New York: Taylor & Francis).
- LANGRAN, G., 1993, Issues of implementing a spatiotemporal system. *International Journal of Geographical Information Systems*, **7**, pp. 305–314.
- MAIDMENT, D.R., 1996, Environmental modeling within GIS. In M.F. Goodchild, L.T. Stayaert, B.O. Parks, D. Johnston, D.R. Maidment, M. Crane and S. Glendinning (Eds). *GIS and Environmental Modeling: Progress and Research Issues*, pp. 147–167 (New York: Oxford University Press).
- MAIDMENT, D.R. (Eds), 2002, *ArcHydro: GIS for Water Resources* (Redlands, CA: ESRI Press).
- MARTIN, P.H., LEOEUF, E.J., DOBBINS, J.P., DANIEL, E.B. and ABKOWITZ, M.D., 2005, Interfacing GIS with water resource models: a state-of-the-art review. *Journal of the American Water Resources Association*, **41**, pp. 1471–1487.
- PEUQUET, D.J., 2001, Making space for time: issues in space–time data representation. *Geoinformatica*, **5**, pp. 11–32.
- PEUQUET, D.J. and NIU, D.A., 1995, An event-based spatiotemporal data model (ESTDM) for temporal analysis of geographical data. *International Journal of Geographical Information Systems*, **9**, pp. 7–24.
- RASINMAKI, J., 2003, Modelling spatio-temporal environmental data. *Environmental Modelling and Software*, **18**, pp. 877–886.
- RECKHOW, K., BAND, L., DUFFY, C., FAMIGLIEI, J., GENEREUX, D., HELLY, J., HOOPER, R., KRAJEWSKI, W., MCKNIGHT, D., OGDEN, F., SCANLON, B. and SHABMAN, L., 2004, Designing hydrologic observatories: a paper prototype of the Neuse watershed. Technical report (Austin, TX: CUAHSI).
- REW, R. and DAVIS, G., 1990, NetCDF – an interface for scientific-data access. *IEEE Computer Graphics and Applications*, **10**, pp. 76–82.
- SINGH, V.P. and WOOLHISER, D.A., 2002, Mathematical modeling of watershed hydrology. *Journal of Hydrologic Engineering*, **7**, pp. 270–292.
- SOOD, C. and BHAGAT, R.M., 2005, Interfacing geographical information systems and pesticide models. *Current Science*, **89**, pp. 1362–1370.
- SRINIVASAN, R. and ARNOLD, J.G., 1994, Integration of a basin-scale water quality model with GIS. *Water Resources Bulletin*, **30**, pp. 453–462.
- SUI, D.Z. and MAGGIO, R.C., 1999, Integrating GIS with hydrological modeling: practices, problems, and prospects. *Computers, Environment and Urban Systems*, **23**, pp. 33–51.
- TIM, U.S. and JOLLY, R., 1994, Evaluating agricultural nonpoint-source pollution using integrated geographic information systems and hydrologic/water quality model. *Journal of Environmental Quality*, **23**, pp. 25–35.
- WANG, J., HASSETT, J.M. and ENDRENY, T.A., An object oriented approach to the description and simulation of watershed scale hydrologic processes. *Computers and Geosciences*, **31**, pp. 425–435.
- YUAN, M., Representation of space and time. *Economic Geography*, 2004, **80**, pp. 217–218.